

Operating instructions

Railcar Trailer Hitch

80800 with indication

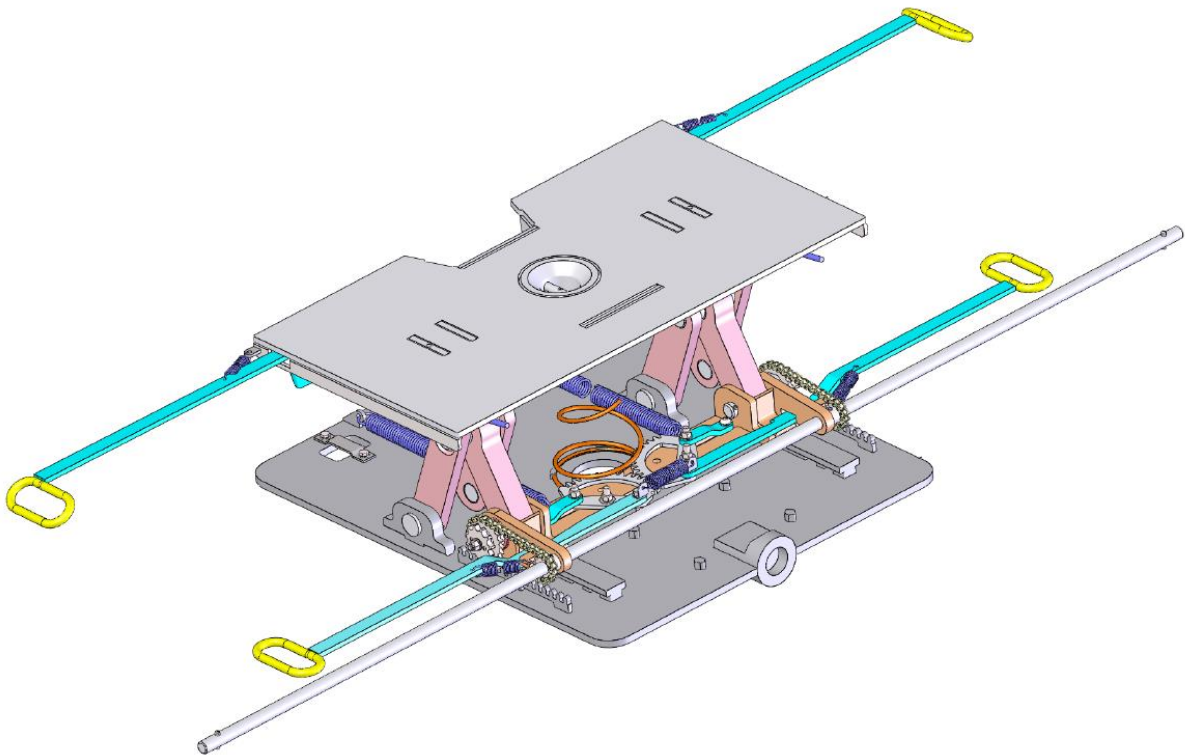



The hitch operation can be executed from both sides.

When setting the hitch height, it should be noted that only one person operates the height adjustment! No persons should be at risk!

1. Make a visual check of the hitch

Before applying any load, the hitch should be checked for visible signs of damage. Loads must not be applied to damaged hitch.

2. Setting the hitch height

The hitch height is to be adjusted according to modification of the semi-trailer (88cm, 98cm, 113cm) as follows:

- Insert the T-keys onto the shaft (base plate 70800 position 10)

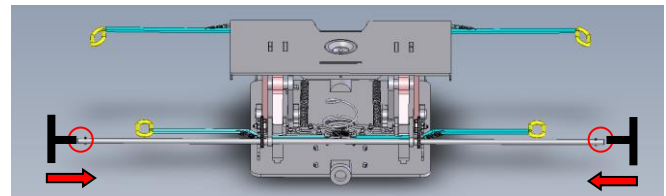

- Discharge the system by turning the T-key in the direction of the buffer from the carriage

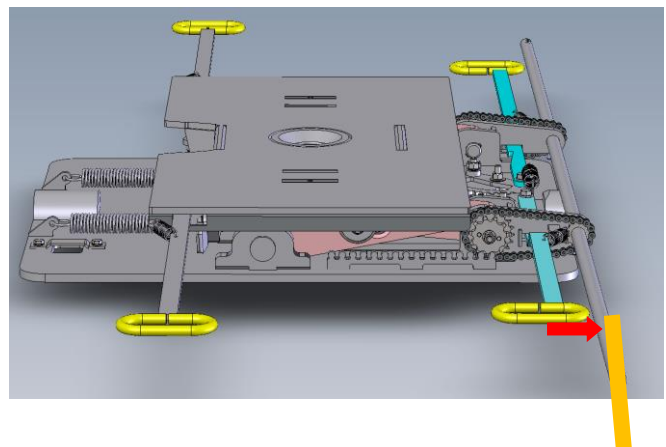

- Hold the T-key



- Lock the height adjustment by pulling the release lever (base plate 70800, pos. 28 or 29) away from the shaft at toward the end of the carriage respectively, then mount the release lever.

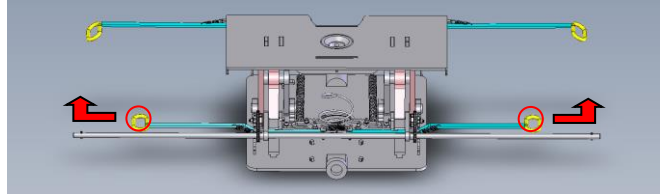

- Carry out height adjustment by turning the T-key

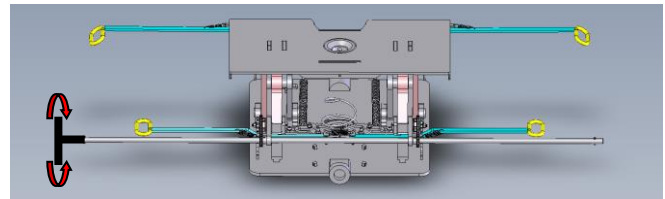

- **Visual inspection: Locks must be completely engaged on both sides!**

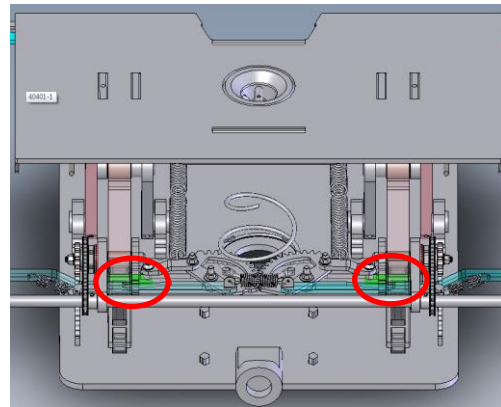

Height adjustment information:

The hitch automatically locks when the next height adjustment is reached. A further unlocking of the height adjustment is therefore necessary with the height adjustment from 113cm to 88cm (and vice versa) after the height of 98cm is reached!

When setting the height adjustment at 88cm, the spring tension has to be overcome to engage the lock.



3. Loading procedure

ALWAYS LOAD WITH A SUPERVISOR!

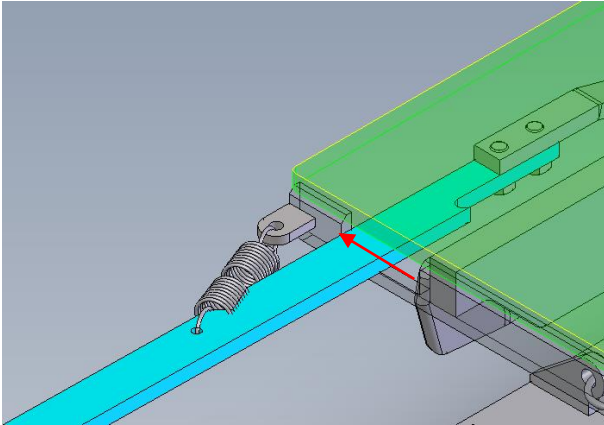

(The hitch plate hand lever has to be at the limit in the direction of the spring)

The semi-trailer has to be located over the railcar pocket. The semi-trailer king pin is to be positioned over the hitch funnel!

The lock is positioned in a locked state prior to loading.

Lower the semi-trailer until it rests on the hitch plate.

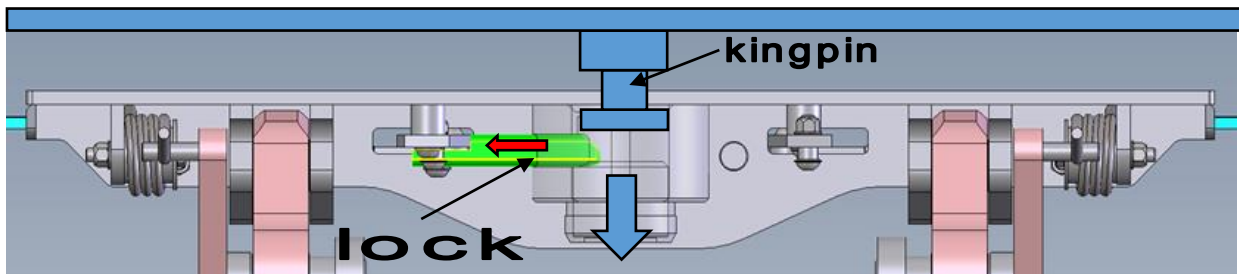

(The king pin automatically opens the catch during loading)

The semi-trailer is positioned and then locked in the hitch funnel

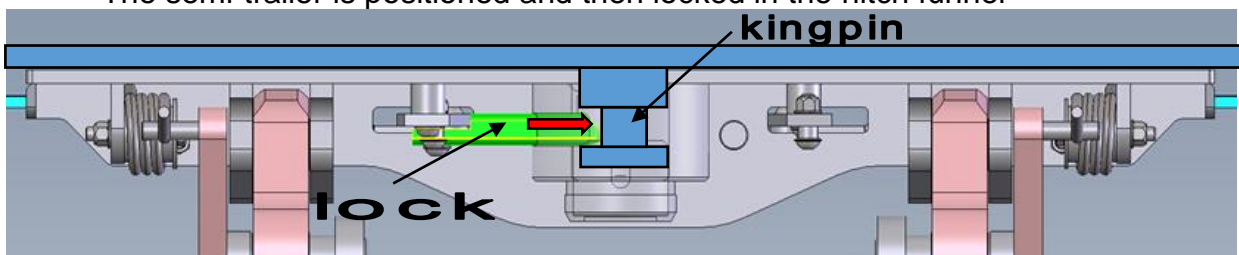

(The catch automatically locks)



Correct

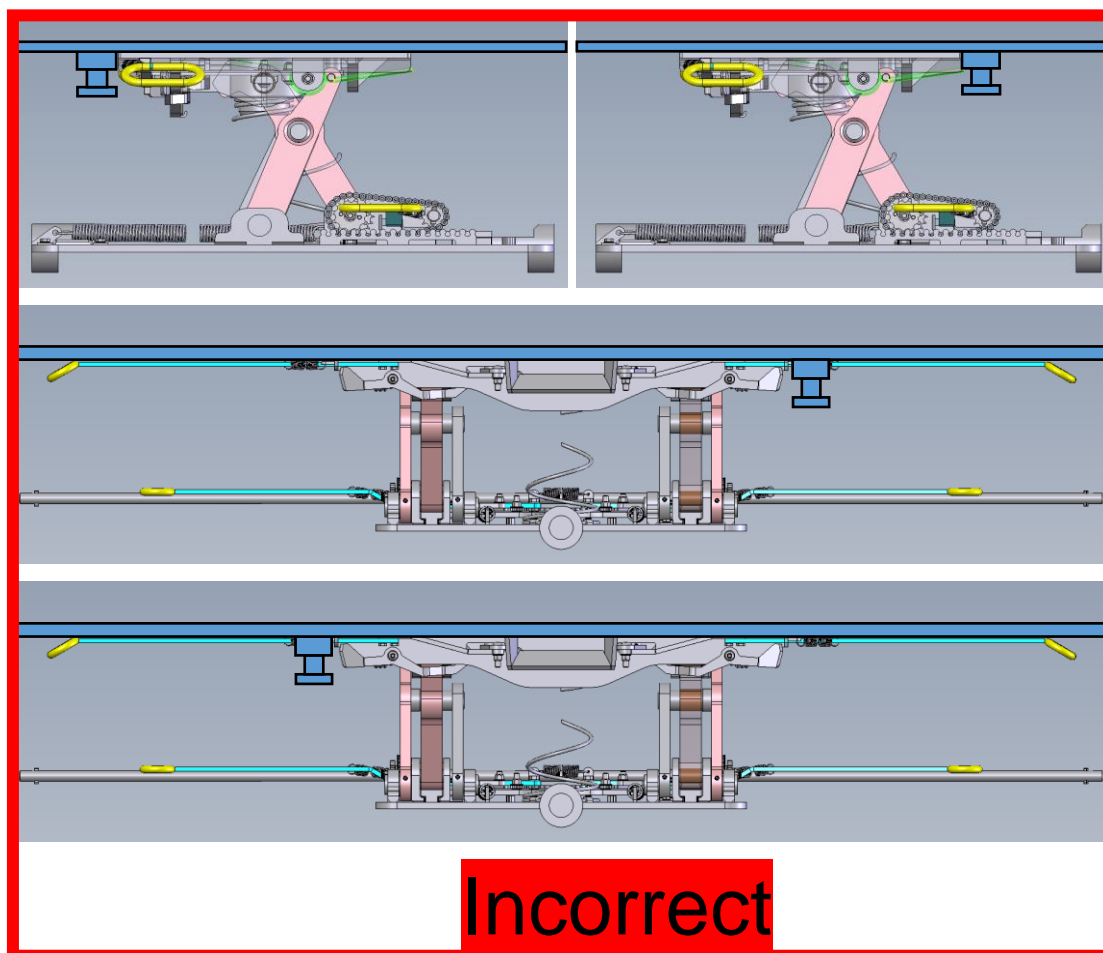
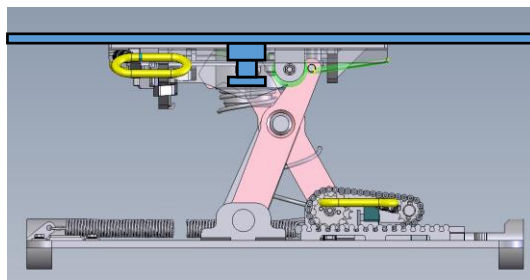



For hitch variants 2 and 3 according to drawing 80800 (index F) there is the following additional display.

The following indicator helps the user discern whether the kingpin is positioned in the funnel.

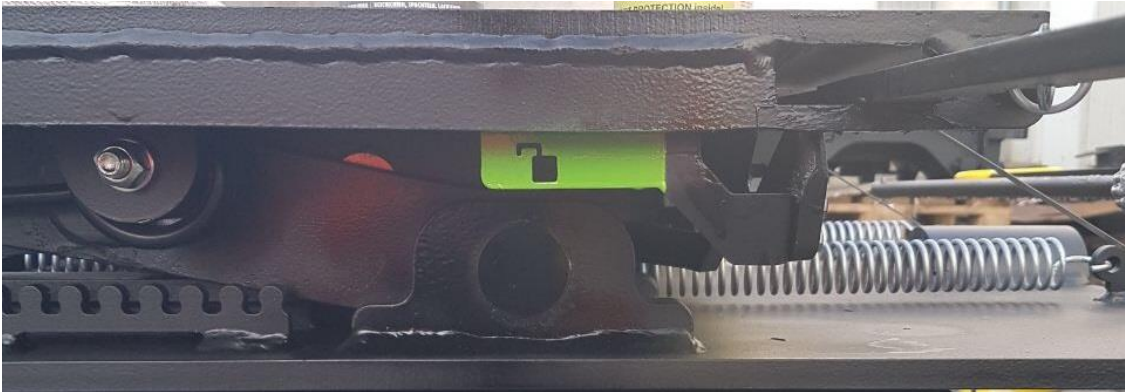

As long as the indicator (red or green > dependant on the customer) is visible, the king pin is not in the funnel. Not the indicator is not longer visible, is the kingpin situated in the funnel.

4. Visual inspection of the load

The semi-trailer has to rest flat on the hitch plate and there must not be a gap between the semi-trailer and the hitch plate.

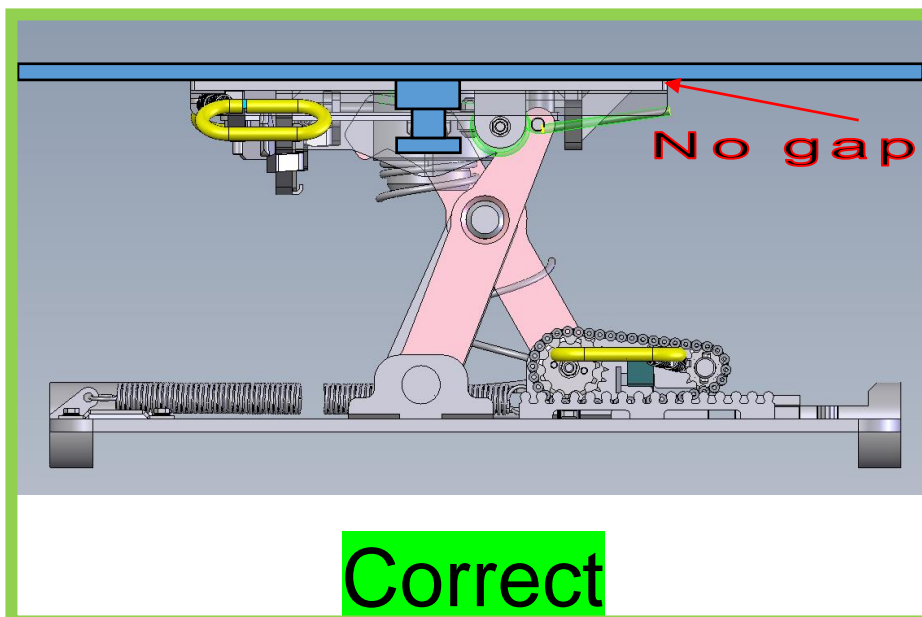

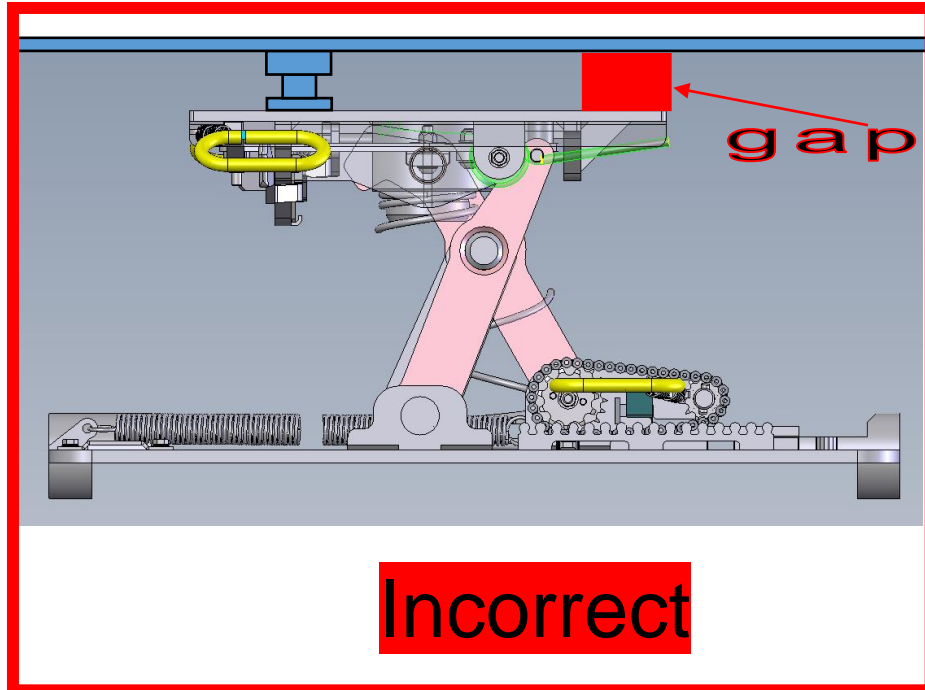
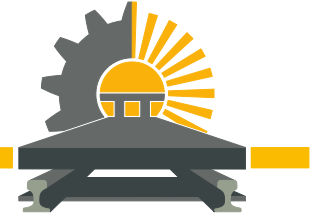

The king pin is correctly locked if the king pin lock release lever (hitch plate 70400; pos. 16 and 17) is at right angles to the hitch plate!

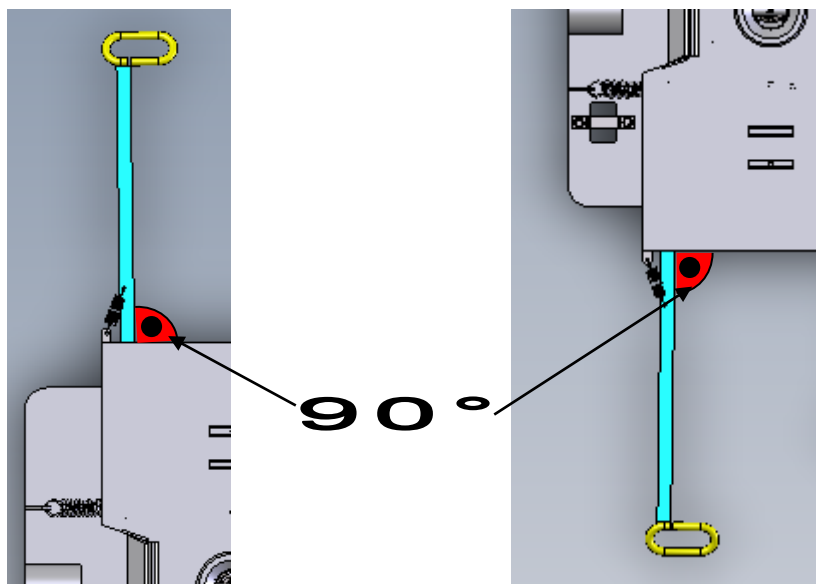

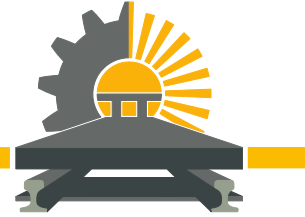

5. Adjustment (as required)

Before any adjustment work involving cranes commences, it should be ensured that the kingpin is released!

The following should be noted during loading of containers or interchangeable tanks onto the pocket wagon.

The hitch has to be positioned and locked on the lowest position (88cm in height).

After meeting this condition, the pocket wagon may be loaded with a container and / or interchangeable tanks.

6. Unload the pocket wagon – lift the semi-trailer release the king pin lock

Move the kingpin locking release lever (move hitch plate 70400, Pos. 10/11, in the direction of the wagon centre and mount.

The unlocked state remains unchanged, the semi-trailer may be lifted immediately or as required.

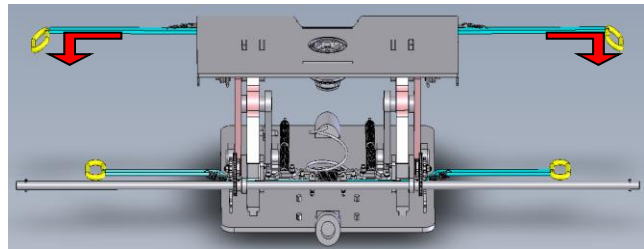

Caution

Strong wagon vibrations (connecting the locomotive) or repeated lifting of the semi-trailer will result in the locking of the kingpin!

In such cases, a further unlocking of the kingpin is required in advance of lifting the semi-trailer.